

Solar Heating System Factsheet (SHSF) Accompanying document

The factsheet is a summary of the test of a solar domestic hot water system. Every factsheet corresponds to a system test number “Snnn” and its test report. The test is only valid for the tested system configuration. The test report is not available on the web site of SPF, since it is owned by the contract party. The content of the factsheet is divided into the following sections:

- Manufacturer’s data
- Type of test (performance measurement, durability test, test procedure according to the Scheme Rules of Solar Keymark)
- System data
- Annual performance prediction, determined according to EN 12976:2006 for “factory made systems”



Solar Heating Systems Factsheet

AH 300/2 — Model name of the solar heating system

Snnn

System test number
e.g. S123



System has successfully passed the performance and quality test

System model	AH 300/2
System type	Thermosyphonsystem
Manufacturer	Company
Address	Street CH-8640 Rapperswil
Phone	+41 055 1111112
Fax	+41 055 1111113
E-mail	
Internet	
Date of test	08. 2008

Performance test EN12976:2006
 Quality test EN12976:2006

SolarKeymark



System-Data	Types of collector mounting
No. of collector modules/pipes	1/20
Gross collector area	2.21 m ²
Storage tank volume	280 l
Design load¹⁾	140 l/d
Gross dimension flat roof (LxWxH)	1950 mm x 2140 mm x 2000 mm
Gross dimension sloping roof (LxW)	2550 mm x 2140 mm

Only the test procedures with a checkmark were successfully performed.

The technical description of the system starts with the section “System-Data” and includes information about the system and its components.

Required space: Gross dimensions of thermosiphonsystem or integral collector-storage system

Installation on flat roof

Note:
Width W see figure
below.

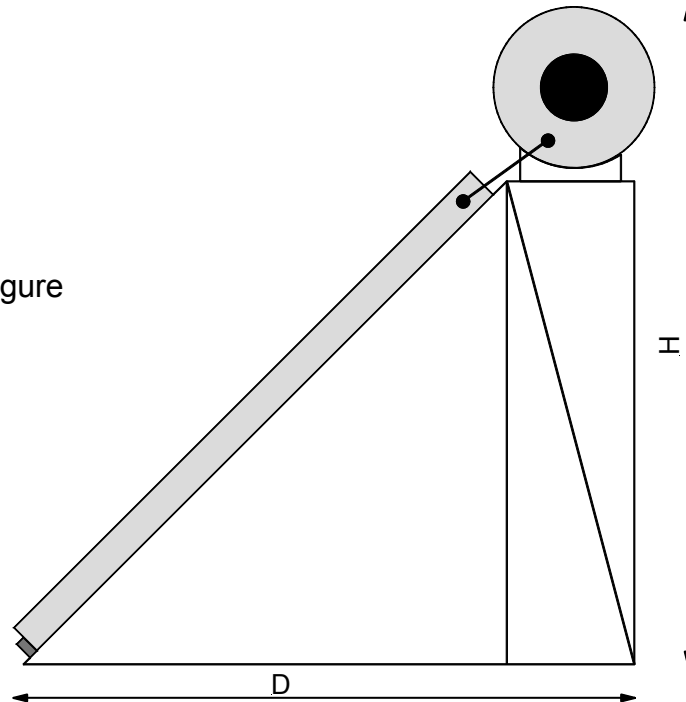

Installation on tilted roof

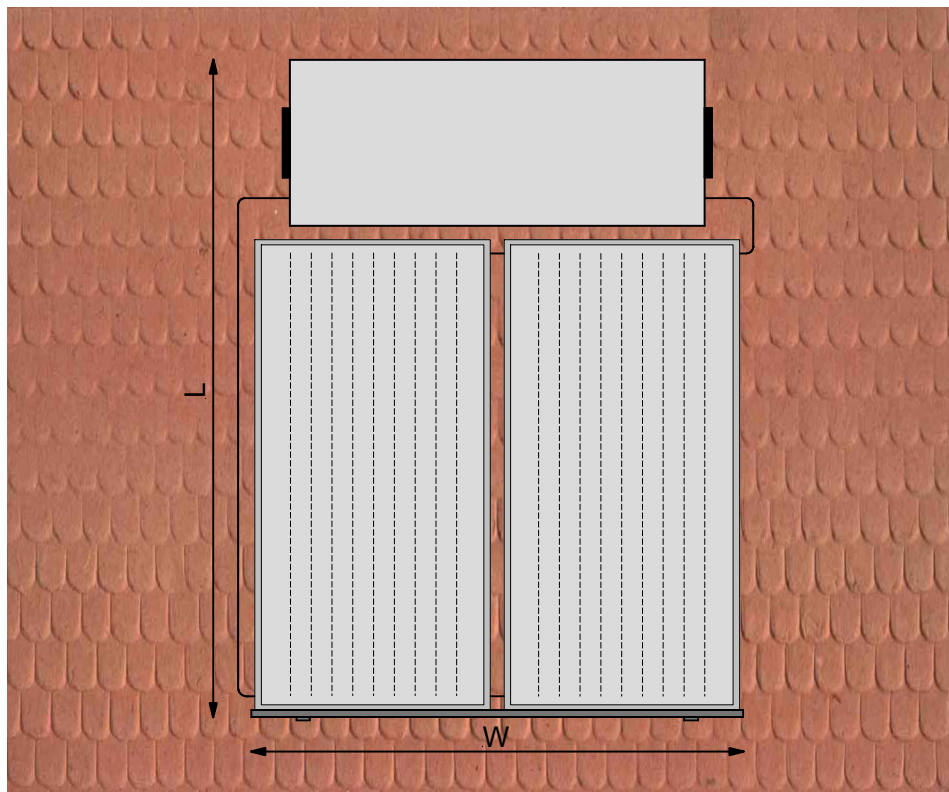

Required space: Collector array of a forced-circulation system

For forced-circulation systems refer the gross dimensions of the following installations to the collector array.

Installation on tilted roof

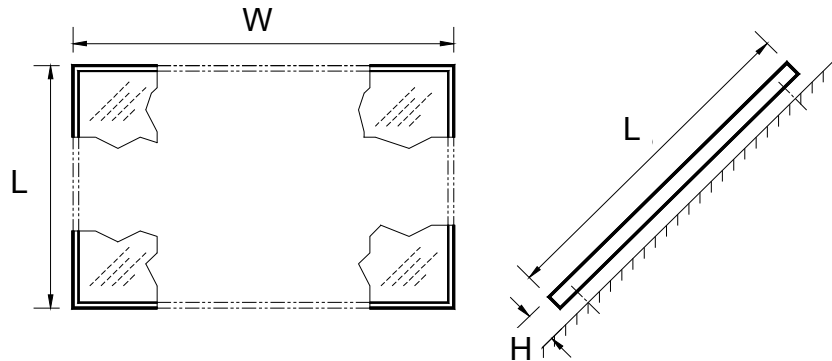

W: Width without connections

L: Length without fastening elements and connections

H: Distance from roof

Integration into tilted roof

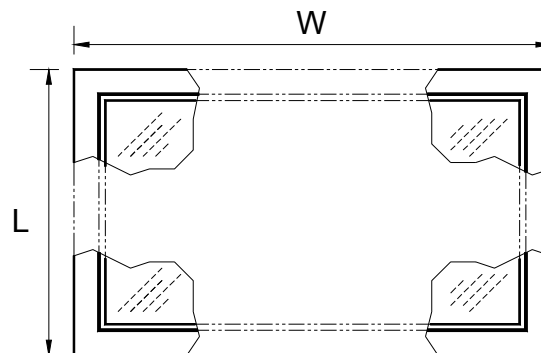

W: Width of the roof joint plates or tiles substructure

L: Length of the roof joint plates or tiles substructure

Construction on flat roof

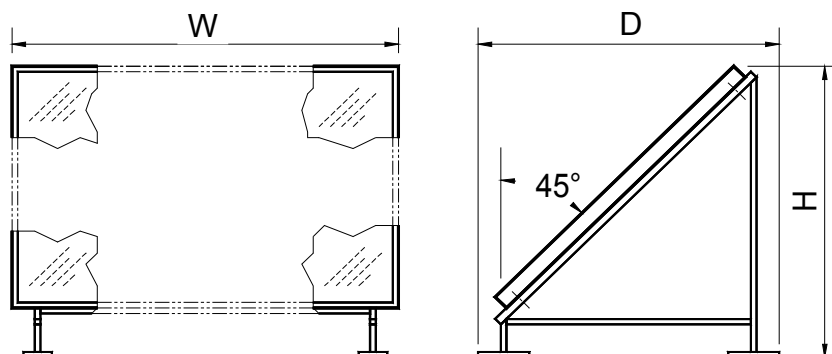

W: Width of the collector row, without connections

D: Depth of the collector row

H: Distance between top edge and roof

Space requirement: Gross dimensions of forced-circulation systems storage tank

Minimum ceiling height

The limit is given by the tilted height. Hot water connections or other components on the upper side of the tank could also limit the height.

Clearance required for installation

Decisive is the side view of the storage tank with the smallest width. It is stated if the clearance required for installation can be reduced by dismantling the insulation.

Footprint

Footprint including connections and system components. For maintenance works additional place is allowed, but is not considered here (e.g. sacrificial anode, electrical heater, etc).

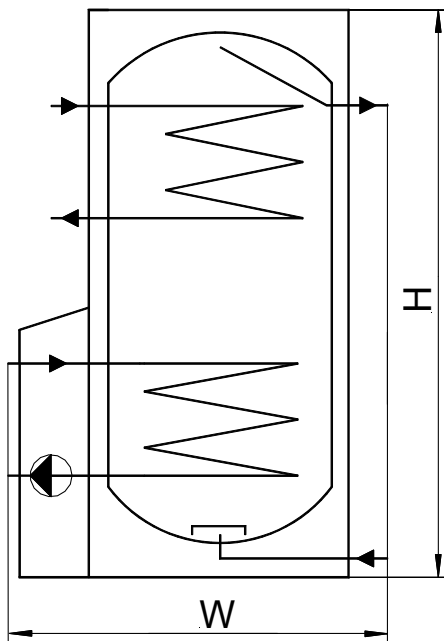

H: Height of storage tank including tank connections if they are placed on the upper side^{*)}

W: Width including attached components and connections^{*)}

D: Depth including connections^{*)}

^{*)} 150 mm for piping, bends and thermal insulation is additionally provided.

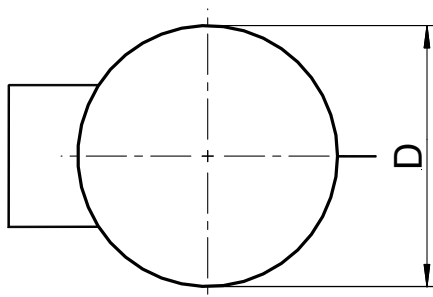

Abbreviations:

HE – Heat exchanger

Annual performance presentation

The performance presentation is in accordance with EN 12976:2006, the European test standard for factory made systems for domestic hot water heating.

Factory made systems are batch products with one trade name, sold as complete and ready to install kits with a fixed configuration.

The following four locations are defined by the standard, to make the test results comparable and to consider different climate conditions for the annual performance presentation. Every location represents a particular climate:

Locations	Represented Climate
Athens (GR)	Southern Europe
Davos (CH)	Mountain area
Stockholm (SE)	Northern Europe
Würzburg (DE)	Central Europe

The annual performance is shown in the factsheet for every location. The load volume in litres per day is the volume of hot water, which is withdrawn every day at a water temperature of 45°C.

The load volume is being chosen from the following series to facilitate comparison of the performance of different systems (if larger loads are required, the series might be extended).

⇒ 50 l/d, 80 l/d, 110 l/d, 140 l/d, 170 l/d, 200 l/d, 250 l/d, 300 l/d, 400 l/d, 600 l/d

The **design load** depends on the store volume, type and the thermal characteristics of the storage tank. The manufacturer shall give a design load for the system. The annual performance is calculated for a range of load volumes in the interval of 0.5 times and 1.5 times the design load.

The **performance data** are given in SI-units for energy in „MJ per year“.

For solar-only and solar preheat systems

Q_d	Heat demand; depending on the climatic conditions and the daily load volume
Q_L	Heat delivered by the solar heating system (load) under the climatic conditions
$f_{sol} = \frac{Q_L}{Q_d}$	Solar fraction
Q_{par}	Parasitic energy (electricity) e.g. for pump, controller etc. which the system requires during operation

Note: To convert MJ into kWh divide the values by “3.6”.

For solar-plus-supplementary systems

Q_d	Heat demand; depending on the climatic conditions and the daily load volume
$Q_{aux,net}$	Net auxiliary energy demand of a solar heating system delivered by the auxiliary heater to the store directly to the distribution system
Q_{par}	Parasitic energy (electricity) e.g. for pump, controller etc. which the system requires during operation
f_{sav}	Fractional energy savings

Fractional energy savings for solar-plus-supplementary systems

In accordance with prCEN/TS 12977-2:2008

Reduction of purchased energy achieved by the use of a solar heating system, calculated as the ration of the difference between the energy used by conventional heating system and auxiliary energy used by solar heating system to the energy used by conventional heating system – defined in the EN ISO 9488.

$$f_{sav} = (Q_{conv} - Q_{aux})/Q_{conv}$$

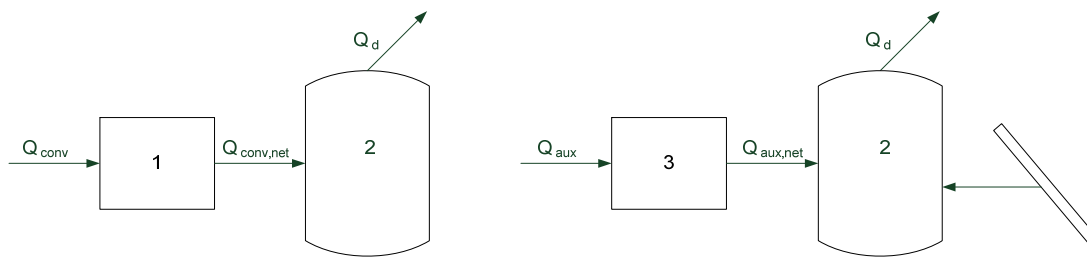

Conventional heating system
(reference system)

Solar heating system

Both systems are assumed to use the same kind of conventional energy and to supply the user with the same heat quantity giving the same thermal comfort. For the solar heating system, calculate the gross auxiliary energy demand by:

$$Q_{aux} = Q_{aux,net}/\eta_{aux} \quad \text{with} \quad \eta_{aux} = 0.75$$

- 1 heater, η_{conv}
- 2 storage tank
- 3 auxiliary heater, η_{aux}
- 4 collector
- Q_{aux} gross auxiliary energy demand
- $Q_{conv,net}$ net energy demand of the conventional heating system
- Q_{conv} gross energy demand of the conventional heating system
- η_{aux} overall generation efficiency of the auxiliary heater of the solar heating system
- η_{conv} overall generation efficiency of the auxiliary heater of the conventional heating system

Reference system:

Heat demand, net energy demand and gross energy demand for the reference system (on annual base)			
V_d (daily) l/d	$Q_d (= Q_L)$ MJ	$Q_{conv,net}$ MJ	Q_{conv} MJ
50	2650	3809	5079
80	4241	5706	7608
110	5831	7550	10066
140	7421	9360	12480
170	9011	11148	14864
200	10601	12919	17225
250	13252	15843	21124
300	15902	18741	24988
400	21203	24481	32641
600	31804	35819	47759

The definition of one single European reference system allows for comparison of test results of different systems based on the same reference. The fractional energy savings is meant only to compare solar heating systems to other solar heating systems, and should not be used to compare conventional heating systems to solar heating systems or to other conventional heating systems.

Reference conditions for performance presentation for European locations

The following reference conditions are in accordance with EN 12976:2006

Collector tilt angle	45°
Collector orientation	South
Draw-off flow rate	10 dm ³ /min
Daily load volume	50 to 600 litres per day
Daily load pattern	100 % ¹ , at 6 h after solar noon ²
Desired temperature T _D (if the temperature exceeds T _D , cold water is added to reach T _D .)	45°C
Cold water supply temperature	s. the following table
Store ambient temperature For systems where the store is located outdoors, the ambient temperature from the climate data shall be used.	15°C
Temperature set point of integrated auxiliary heater	52.5°C

Data for calculation of the cold water temperature and the energy of solar radiation received in the collector array over one year at the reference locations.

	Average cold water temperature [°C]	Solar radiation [kWh m ⁻² a ⁻¹]	Ambient temperature [°C]
Athens	17.8 ± 7.4	1338	17.7
Davos	5.4 ± 0.8	1684	3.2
Stockholm	8.5 ± 6.4	1113	6.9
Würzburg	10.0 ± 3.0	1230	9.0

¹ The draw-off profile (100 %, six hours after solar noon) does not give a typical profile of a household. It has been chosen to facilitate comparison of the performance data of the two different test methods – part 2 and part 5 of ISO 9459.

² The withdrawal of hot water is done six hours after solar noon. “Solar noon” is defined as the moment, which divides the hours of daylight (between sunrise and sunset) in half. The “solar noon” is the moment of a geographical location, when the sun reaches its highest position.