

EXPERIMENTAL INVESTIGATIONS ON CHARGING AND DISCHARGING STRATEGIES OF THERMAL ENERGY STORES AND THEIR EFFECT ON SYSTEM EFFICIENCY

Robert Haberl, Elimar Frank

Institut fuer Solartechnik SPF, HSR University of Applied Science of Rapperswil,

Oberseestr. 10, 8640 Rapperswil, Switzerland

Abstract

For solar thermal combisystems, different storages and corresponding charging and discharging concepts are available, e.g. with immersed or external heat exchangers and/or internal or external stratification concepts. In several publications the effect on the system performance is discussed based on simulations and/or test sequences which are representing constricted operating conditions (Han, 2009; Logie, 2010; Lohse, 2010). To achieve a more compelling assessment based on experiments, a combisystem with four different storage and storage integration concepts were tested under realistic load conditions, using the Concise Cycle Test (CCT) method. The common features of all tested systems are the auxiliary heater and the solar collectors as well as the storage volume. Different hydraulic schemes were used for the systems tested to connect these components with the storage. Both immersed and external heat exchangers were used for charging (by the solar collectors) and discharging (domestic hot water preparation) the storage.

The experiments revealed a considerable range of annual fuel consumption (+/- 5 %) to cover an identical load, although only the charging and discharging strategies at the storage has been changed whereas the components for heat supply and the energy demand were identical. In the system configurations tested, the integration of the condensing heating oil fired boiler turned out to be particularly important because the utilisation of latent heat (condensation) is strongly dependent to the resulting return temperatures of the boiler.

Furthermore it was shown that the integration of a stratification device for volume flows entering the store leads to a fuel reduction, even in a system whose hydraulic scheme and control strategy were optimised to charge and discharge the thermal energy store according to the storage temperatures.

The system that uses an immersed coil heat exchanger for domestic hot water preparation had to keep a particularly large part of the thermal energy store at high temperatures to be able to cover the comfort requirements. In the case investigated, in combination with a store that has considerable heat losses this led to a less efficient system (- 5 %) compared to tests with a buffer store and external domestic hot water heat exchanger.

1. Motivation

The challenge of systems that combines solar energy with conventional energy sources for combined domestic hot water (DHW) preparation and space heating (SH) is to integrate two different heat sources into a single system that covers the comfort requirements in a reliable and cost-effective way. In that context, the thermal energy store (TES) and its charging and discharging strategy is decisive because it influences the operation conditions and thus the performance of the other components (namely the solar collectors and the auxiliary heater). According to this, an isolated test of the TES is likely not to reveal the overall system performance. Instead of that, it is conducive to test complete systems to draw a comparison of different storage concepts. Furthermore, the tests should allow an assessment on a yearly basis rather than describing only some of the occurring system operating conditions.

2. Method

For the experimental analysis of the systems, a dynamic test cycle called the Concise Cycle Test (CCT) has been used (cf. Vogelsanger, 2002). There, the boundary conditions of climate and a typical load from a reference year are applied in a 12-day test cycle (where every day represents a month in the Swiss Midlands climate) to emulate realistic conditions. The combisystem must be installed completely on the test rig just as it would be installed in a commercial situation (e.g. a single family house). Only the collector is not installed but emulated using an electrical heating and cooling circuit so that the realistic collector output is delivered to the system for each timestep. The system must completely act autonomously to cover the heat demand of the building and the draw-offs. The decisive quantity that is used to characterise the system performance later on is the measurement of the auxiliary energy consumption. Figure 1 shows the concept of laboratory testing with the CCT method.

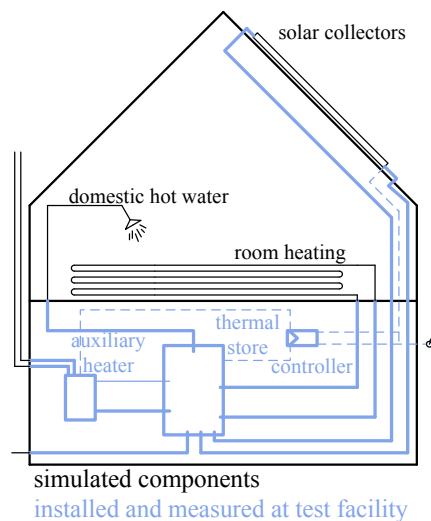

Figure 1: Concept of laboratory testing with the CCT method. The house with heating distribution and the collectors are simulated or emulated. Auxiliary heater and thermal storage, as well as all piping, control devices etc. are installed and tested.

The scaling of the performance indicators of the 12-day period to annual indicators would not lead to precise results because of the thermal capacities of the TES and the virtual building. Therefore, subsequent to the physical test sequence the acquired data are used to validate a system simulation model that is further used to evaluate the system in light of annual performance summaries. The simulations were performed using the simulation program TRNSYS (Klein et al., 2000).

3. Systems tested

The common features of all tested systems are the parameters and characteristic of the auxiliary heater and the solar collectors. The system integration of these components has been solved with differing specific hydraulic schemes in the systems tested. Thereby, both immersed and external heat exchangers were used in the charging (by the solar collectors) and discharging (DHW preparation) of the store.

Components of the systems tested

Two different thermal energy stores (TES) have been investigated in this work. TES-A is a buffer store with no immersed coil heat exchangers (IHX). All incoming flow rates enter TES-A through an internal stratification device. In contrary, TES-B contains two IHX: One for DHW preparation (containing drinking water) and one for charging the TES with the solar collectors (containing a water/glycol mixture). The physical parameters are shown in Table 1.

Table 1: Cardinal physical parameters of the TES tested.

| | TES A | TES B |
|---------------------------------|--------------|----------------------------|
| weight (empty) | 155 kg | 224 kg |
| material | S235JR | black steel |
| nominal volume | 920 l | 1000 l |
| diameter (including insulation) | 990 mm | 1060 mm |
| diameter (without insulation) | 790 mm | 850 mm |
| Stratification device | yes | no |
| DHW-IHX | | |
| material | – | corrugated stainless steel |
| capacity | – | 33 l |
| surface area | – | 7.2 m ² |
| Solar-IHX | | |
| material | – | smooth stainless steel |
| capacity | – | 14 l |
| surface area | – | 2.1 m ² |

In all tests an identical auxiliary heater was used. The device used is a condensing oil fired boiler with a continuous power modulation in the range of 5 to 15 kW with both the boiler circuit pump and the controller integrated. Table 2 shows the specification of this boiler.

Table 2: Specification of the auxiliary heater used in the experiments.

| | |
|---|--|
| nominal heating power | 5 – 15 kW |
| permissible fuel | low-sulphur heating oil; max. sulphur content: 50 mg/kg |
| utilisation of latent heat (condensation) | yes |
| controller | integrated in boiler |

The solar collectors are emulated by the test rig according to a real-time simulation with TRNSYS that takes both the climatic conditions (radiation and temperature) and the real measured data of the return temperature and flow rate into account. It emulates the operation and the non-operation conditions. The coefficients of the efficiency curve of the 15 m² flat plate collector field are:

$$\eta_0 = 0.70$$

$$a_1 = 3.38 \text{ (W/(m}^2\text{K))}$$

$$a_2 = 0.01 \text{ (W/(m}^2\text{K}^2\text{))}$$

Hydraulic schemes

In total, four different systems have been tested with the CCT method. TES-A has been used for the tests #1 to #3 with different hydraulic schemes, and TES-B was assembled in test #4. For test #3, a modified version of TES-A has been used where the internal stratification device has been removed.

System Test #1

The hydraulic scheme used for the first test was kept as simple as possible while using TES-A. Each hydraulic circuit was connected to the store with two ports for the supply and return line. All volume flows enter the TES through a stratification device. Where necessary an external HX was used to separate fresh water or brine from the water in the TES (see Figure 2). If the temperature of the water in the TES is not sufficient to cover the heat demand for SH and DHW preparation the TES is charged by the auxiliary heater. The control is set to allow operation only with nominal power (no power modulation). Both the hydraulic schema and the control strategy are intended to allow a user-friendly installation and a wide variability (e.g. connection of different auxiliary heaters, different heating loads).

System Test #2

Again, TES-A is the core element of test #2. All circuits are connected directly to it. Thus, the auxiliary heater can still not deliver heat directly to the SH loop, but instead of that the TES must be charged. In contrary to test #1 the auxiliary heater is connected with specific ports for charging the upper part of the TES (for DHW preparation) with high temperature or the part of the TES that is reserved for SH with a set temperature according to the heating curve. Switching between the operating modes is realised with two three-way valves (see Figure 3) that switches both the return and the flow line. The control of the auxiliary heater allows a power modulation to reach the respective set temperature (with a fixed flow rate). The changes were implemented as an intermediate step to get to system test #3.

System Test #3

Both the concept and the hydraulic scheme from test #3 correspond to that of test #2. The only difference is that in test #3 all stratification devices in TES-A have been removed (see Figure 4). By integrating the three-way valves, the flow rates are, however, guided in advance to the part of the TES with the corresponding temperature. The core question to be answered was whether a hydraulic optimisation such as implemented in test #2 is leading to equally good or even better results compared to test #1.

System Test #4

The system concept investigated in test #4 differs from the systems described above due to the deviating storage specification of TES-B that has been used for test #4. The hydraulic scheme was adapted (see Figure 5) according to the concept of TES-B: The **solar** heat is transferred to the water of the TES by an IHX. The flow through the collector is controlled by the control unit and the variable speed pump. **DHW** preparation is implemented with a second IHX containing fresh water. A thermostatic mixing valve prevents excessively high water temperatures at the tap. The capacity of the IHX allows the storage of small to medium amounts of DHW. Large draw-off volumes are heated in continuous flow. If the temperature of the water in the upper part of the TES is not sufficient to assure the required DHW temperature the auxiliary heater is started to charge the TES. As in all other system tests, the **SH** is heat coming from the middle part of TES-B, if available (i.e. heated by the solar input). If the temperature of the water in this part of the TES is lower than the set-temperature according to the heating curve, the **auxiliary heater** is started (this is also the case for system tests #2 to #4, but not for #1). The supply line of the heater is connected directly to the SH circuit. In contrary to all other systems investigated, in system #4 the heat for SH is then only coming directly from the auxiliary heater. Because the pump in the burner has a higher flow rate than the SH circuit pump, the SH part of the TES is then loaded with excessive heat from the burner (until the set temperature is reached so that the burner is stopped and the heat for SH is again coming from the storage).

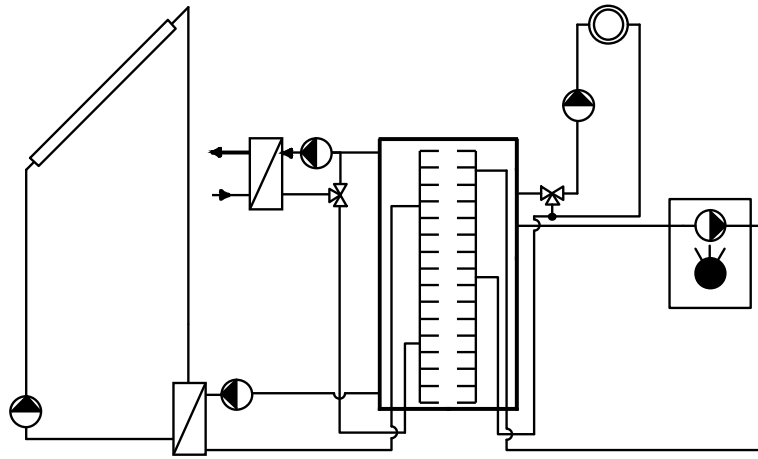

Figure 2: Hydraulic scheme of system test #1. The solar collectors are connected to the store by an external HX. DHW preparation is implemented with an external DHW module (HX, pump and controller). The SH loop and the auxiliary heater are only connected directly to the store. All volume flows enter the TES through a stratification device. The in- and outlet positions are only schematic and not exactly representing the real positions.

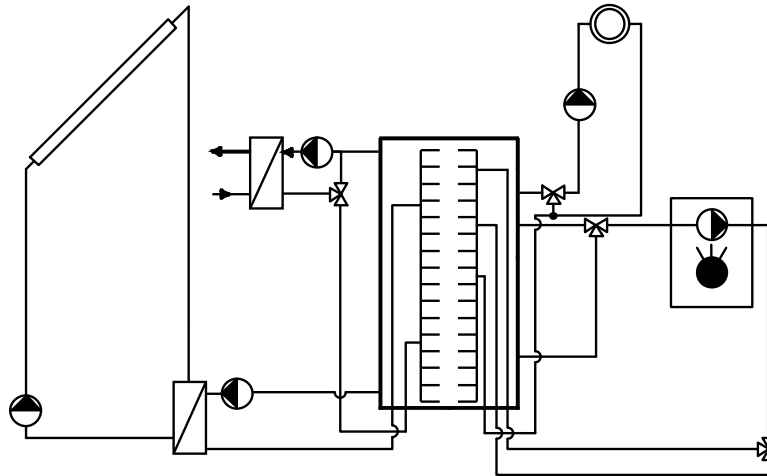

Figure 3: Hydraulic scheme of system test #2. Differing from system test #1, the auxiliary heater is integrated with two three-way valves to switch between the operating modes for DHW-preparation or SH. Again, all volume flows enter the TES through a stratification device.

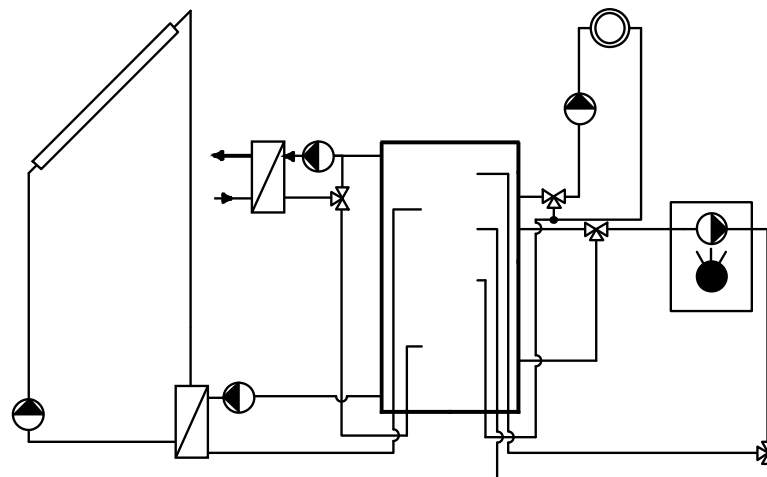

Figure 4: Hydraulic scheme of system test #3. The auxiliary heater is still integrated with two three-way valves to switch between the operating modes for DHW-preparation or SH. Differing from system test #2, all volume flows enter and leave the TES at fixed positions as there are no stratification devices at all in the storage.

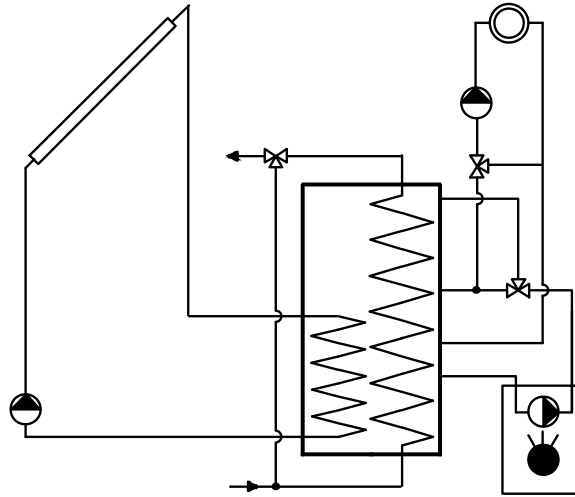

Figure 5: Hydraulic scheme of system test #4. The solar collectors are connected to the store by an IHX. DHW preparation is implemented with another. The SH loop and the auxiliary heater are connected directly to the store. The return line of the auxiliary heater is connected to the lower part of the TES while the supply line has a three-way valve to switch between the operating modes for DHW-preparation and SH.

4. Results

In this chapter both the results of physical test sequences and annual system simulations are described.

Result of physical test sequences

The experimental results of the 12-day tests are summarized in Table 3. To compare the individual tests a so-called energy utilisation ratio was calculated according to eq. 1. With consideration of the input of electric energy the energy utilisation ratio is calculated with eq. 2. For the evaluation in this paper, the electric energy was weighted with the primary energy factor $F_{el} = 3$.

$$\zeta_{S, \text{fuel}} = \frac{Q_{SH} + Q_{DHW}}{Q_{\text{fuel}}} \quad \text{eq. 1}$$

$$\zeta_{S, \text{fuel+el}} = \frac{Q_{SH} + Q_{DHW}}{Q_{\text{fuel}} + F_{el} * E_{el}} \quad \text{eq. 2}$$

The experimental part of the examination shows the functionality of the system and allows a detailed evaluation of the performance. For a direct comparison of the results of each test it has to be noted that the cumulative energy demand for SH in the various tests is not exactly the same. The energy delivered to the building varies between 508 kWh in test #1 to 533 kWh in test #3, with the corresponding effect to the room temperatures. Also, the energy consumption for DHW varies between the external DHW-HX (tests #1, #2 and #3 had an identical energy consumption of 92.1 kWh) and the IHX (88.6 kWh in test #4). For the calculation of the DHW energy consumption both the energy drawn at or above the required temperature was evaluated as well as the energy taken from the storage before the required temperature was reached at the tap.

Not only the energy consumption for DHW and SH varies in the various tests but also the energy input by consuming heating oil and electricity. They range from 479 kWh to 508 kWh (heating oil) or from 15 kWh to 18 kWh (electricity). Nevertheless, to compare the tests of the system concepts the energy utilisation ratio has been used. Here, a difference between systems that uses TES-A and that one using TES-B is clearly visible (the auxiliary heater and the collectors are identical). While the energy utilisation ratio ranges from 123 % to 130 % ($\zeta_{S, \text{fuel}}$) with TES-A the system using TES-B reaches 119 %. When considering the energy input through electricity the difference becomes smaller due to the lower electric consumption in test #4.

The storage temperatures measured during the four CCTs are shown in Figure 6. The temperatures were measured with eight sensors distributed evenly over the height of the respective TES. The measured data of test #1 shows that the temperature profile in the store is good according to the functions of each area. The upper part of the TES is sufficiently hot for DHW preparation while in the lower part enough water is kept with low temperatures to operate the solar collectors efficiently. The changes in the charging strategy with auxiliary energy in test #2 and test #3 led to a slightly increased storage temperature in the lower part of the TES (except for days 7 to 10 when this is less important) because the return line of the boiler for SH is positioned in the lower part. In test #4 it can be seen that the DHW part of the TES is larger compared to the previously tested systems.

Table 3: Result of the physical test sequence. The degree of utilization shown in this table refers to the 12 day test period.
¹ based on the net heating value.

| | | Test #1 | Test #2 | Test #3 | Test #4 |
|---------------------------------------|-------|---------|---------|---------|---------|
| energy input heating oil ¹ | [kWh] | 479.1 | 480.2 | 507.3 | 508.2 |
| energy input electricity | [kWh] | 16.4 | 18.4 | 16.8 | 15.2 |
| energy consumption SH | [kWh] | 507.8 | 526.2 | 532.6 | 514.9 |
| energy consumption DHW | [kWh] | 92.1 | 92.1 | 92.1 | 88.6 |
| mean storage temperature | [°C] | 46.2 | 45.8 | 45.8 | 50.5 |
| boiler starts | [-] | 72 | 53 | 54 | 60 |
| operating time of boiler | [h] | 37.3 | 65.4 | 73.6 | 68.3 |
| $\zeta_{S, \text{fuel}+\text{el}}$ | [%] | 113.5 | 115.5 | 112.0 | 109.0 |
| $\zeta_{S, \text{fuel}}$ | [%] | 125.2 | 128.8 | 123.1 | 118.8 |

Result of annual simulations

The results of the annual simulations are summarised in Table 4. Besides the energy utilisation ratio that is calculated for the system, a energy utilisation ratio was calculated for the auxiliary boiler according to eq. 3, where Q_{water} is the amount of energy balanced on the water side of the boiler and Q_{fuel} is the energy input through heating oil. This was not possible during the 12-day test because the tested systems were not equipped with additional sensors that may affect the system performance (e.g. due to an increased pressure drop). With the help of simulations, these parameters can now be determined.

$$\zeta_{\text{boiler}} = \frac{Q_{\text{water}}}{Q_{\text{fuel}}} \quad \text{eq. 3}$$

The difference between system #1 and system #2 is the strategy to load the TES with heat from the auxiliary boiler. Through the implementation of two three-way valves a reduction was reached of the annual fuel consumption of 1.6 %. The energy utilisation ratio of the boiler is improved from 97.7 % to 100.1 % due to the lower return temperature while loading the SH part of the TES.

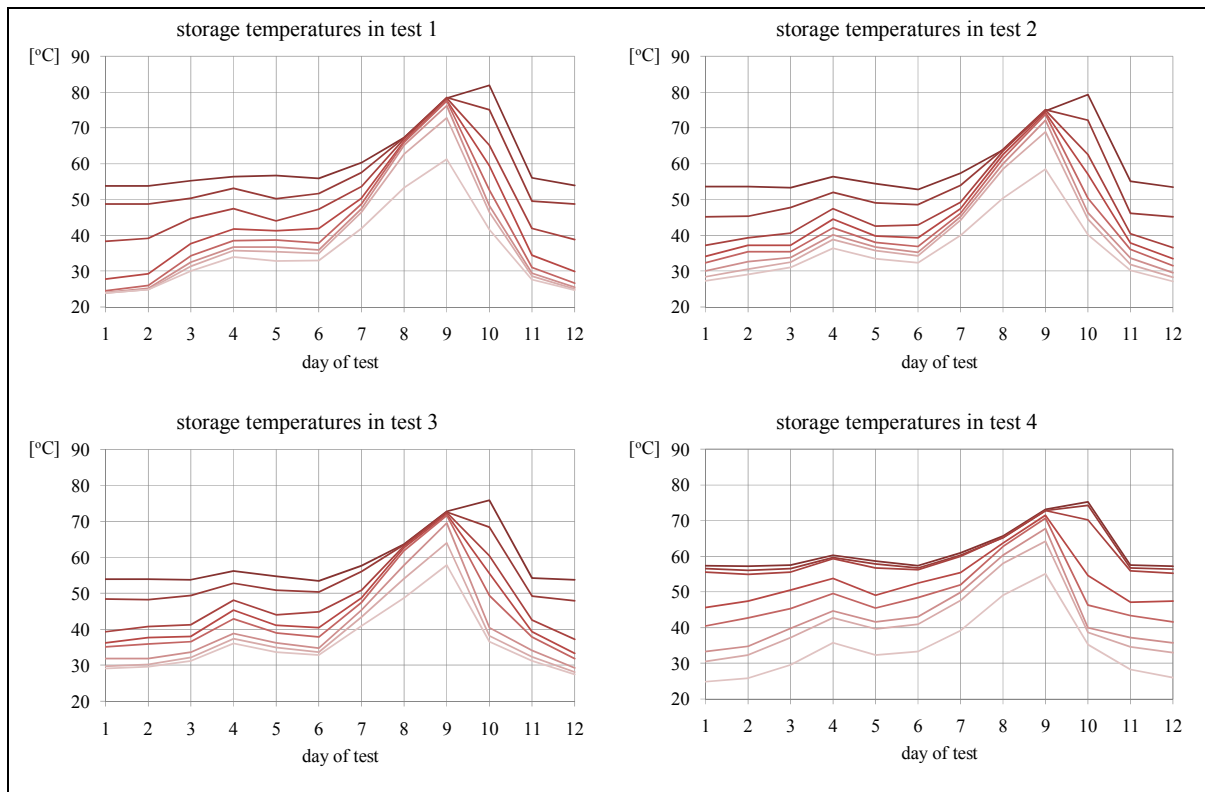

Figure 6: Mean storage temperatures at the 12 days of each CCT, where each day represents the typical climatic conditions of a month. In each case the mean daily temperature of eight measurement points is shown that are distributed equally on the storage height .

The difference between system #1 and system #2 is the strategy to load the TES with heat from the auxiliary boiler. Through the implementation of two three-way valves a reduction was reached of the annual fuel consumption of 1.6 %. The energy utilisation ratio of the boiler is improved from 97.7 % to 100.1 % due to the lower return temperature while loading the SH part of the TES.

In system test #3 the stratification device in TES-A had been removed. Due to the hydraulic optimisation carried out for test #2 in contrary to test #1 an external stratification is implemented. Nevertheless, the fuel consumption in test #3 without the stratification device is higher (+ 2.4 %) compared to test #2.

In accordance to the physical tests, the annual system simulation of system #4 (with TES-B) shows the lowest energy utilisation ratio on system level ($\zeta_{S, \text{fuel}}$), even though the boilers energy utilisation ratio reaches 99.5 %. The fuel consumption amounts to 17.4 MWh (compared to 16.5 MWh with the best configuration of TES-A).

**Table 4: Result of the annual simulations. The degree of utilization shown in this table refers to a period of one year.
¹ based on the net heating value.**

| | | Sim #1 | Sim #2 | Sim #3 | Sim #4 |
|---------------------------------------|-------|---------------|---------------|---------------|---------------|
| energy input heating oil ¹ | [MWh] | 16.8 | 16.5 | 16.9 | 17.4 |
| energy input electricity | [MWh] | 0.3 | 0.4 | 0.3 | 0.3 |
| energy consumption SH | [MWh] | 15.6 | 15.6 | 15.6 | 15.6 |
| energy consumption DHW | [MWh] | 2.8 | 2.8 | 2.8 | 2.8 |
| ζ_{boiler} | [%] | 97.7 | 100.1 | 99.7 | 99.5 |
| $\zeta_{S, \text{fuel}+\text{el}}$ | [%] | 109.9 | 110.7 | 109.3 | 107.2 |
| $\zeta_{S, \text{fuel}}$ | [%] | 116.8 | 118.7 | 116.1 | 113.1 |

5. Discussion

The measurements revealed a difference between the discharging of the TES for **DHW** preparation with an **external DHW-HX** (used in the tests #1, #2 and #3 with TES-A) and the **IHX** used in test 4 (TES-B). The energy consumption with the IHX was noticeably lower due to a shorter time to reach the set-temperature for DHW (compare Table 3). However, this must be looked at in relation to the larger volume in TES-B which is reserved for DHW-preparation in test #4 and the resulting higher storage temperatures (compare Table 3 and Figure 6), particularly with the effect of higher losses to the ambient of test #4.

The **charging strategy with auxiliary energy** in test #1 led to a very good temperature distribution in the TES with a large volume with low temperatures in the lower part of the TES. By the use of the modified charging strategy with auxiliary energy in test #2, the temperature distribution was negatively affected (compare Figure 6). Nevertheless, the modified charging strategy led to an improved energy utilisation ratio (compare

Table 4, 116.7 % vs. 118.7 %). The reason is an improved efficiency of the auxiliary boiler by the lower return temperatures resulting in higher condensation gains (97.7 % vs. 100.1 %). However, the hydraulic scheme and the control strategy of the auxiliary boiler implemented in test #2 means considerably more effort in the planning and installation of the system in comparison to test #1. Especially the power control and the regulation of the set-temperatures in relation to the storage temperatures are difficult to apply and comprises an increased potential for errors.

6. Summary and Conclusion

The examination of system #1 showed that this is an efficient system concept that covers the heat demand for SH and DHW in a reliable way. The installation and commissioning is straightforward, the hydraulic scheme and the control is comparably easy to understand and to implement.

Changing the strategy for charging the TES with auxiliary energy in test #2 led to a significant improvement in the efficiency of the system, although the temperature distribution in the TES was not as good as in test #1. In particular, the annual efficiency of the condensing boiler could be increased.

In a system whose hydraulic scheme and control strategy was optimised to charge and discharge the TES according to the storage temperatures (test #3) the utilisation of an stratification device in the TES was still leading to a reduction of the fuel consumption by 2 % (comparing system test #3 with #2).

The system concept used for test #4 kept a particularly large part of the TES at high temperatures to be able to cover the comfort requirements for DHW with the IHX. In the investigations presented in this paper, this led to a less efficient system compared to previous tests with a buffer store and external DHW-HX. However, a better comparison can only be done for system concept #4 when the effect of the differing heat losses can be excluded.

The investigations presented in this paper are providing a deeper insight in the effect of charging and discharging strategies of thermal energy stores on the system efficiency, mainly based on comprehensive dynamic system tests and validated annual simulations. Still, for the comparison and the assessment of the different concepts that have been investigated not only the resulting technical measures but also the costs and the error rate potential of the installation and the commissioning of the systems have to be considered.

7. Acknowledgement

The authors would like to express their gratitude to the Swiss Federal Office of Energy and the manufacturers involved for the support of this work.

References

Haberl, R. et al., 2009. Holistic System Testing - 10 Years of Concise Cycle Testing. In: Solar World Congress 2009, Johannesburg, South Africa, 351-360.

Han, Y.M. et al., 2009. Thermal stratification within the water tank. Renewable and Sustainable Energy Reviews, 13(5), pp.1014-1026.

Klein, S.A. et al., 2000. TRNSYS 16, a transient system simulation program – reference manual. Solar Energy Laboratory University of Wisconsin – Madison, Madison, USA.

Logie, W. et al., 2010. Investigation of Immersed Coil Heat Exchangers in regard to Heat Transfer and Storage Stratification. In Graz, Austria.

Lohse, R. et al., 2010. Test von Schichtbeladesystemen unter praxisnahen Bedingungen. Proceedings of 20. Symposium Thermische Solaranlage, Bad Staffelstein, Germany.

prEN 12977-3:2006. Thermische Solaranlagen und ihre Bauteile – Kundenspezifisch gefertigte Anlagen – Teil 3: Leistungsprüfung von Warmwasserspeichern für Solaranlagen.

Vogelsanger, P. et al.: The Concise Cycle Test method – A Twelve Day System Test. IEA SH&C Task 26 Technical Report, 2002.